

20U SERIES

ZIGZAG SEWING MACHINE

Operation manual

parts book

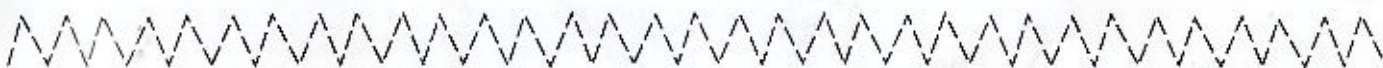
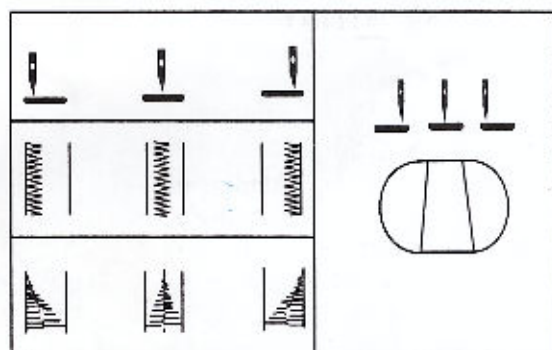

CONTENTS

- I. Brief Introduction of the Machine
- II. Main Technical Specifications and Application
- III. Installation and preparation for operation
 - 1. Installation
 - (1) Fixing of oil Disk
 - (2) Installation of Maching Head
 - (3) Installation of Knee-Control Componet
 - (4) Installation of Motor
 - 2. Preparation for Operation
 - (1) Cleaning the Machine
 - (2) Inspection
 - (3) Lubrication
 - (4) Test Run
- IV. How to Operate
 - 1. Selection of thread
 - 2. Coordination of Needles, Thread and Material
 - 3. Assemblage of Needle
 - 4. Winding Thread around the Bobbin
 - 5. Threading needle & Bobbin thread
 - 6. Mounting of Bobbin
 - 7. Mounting and Dismounting of the bobbin case
 - 8. Adjustment of needle distance and material-feeding
 - 9. Adjustment of pressure of presser Foot
 - 10. Selection of needle position
 - 11. Adjustment of horizontal needle distance
 - 12. Linear Stitching Locking unit
- V. Tension of Thread
 - 1. Adjustment of Bobbin thread Tension
 - 2. Adjustment of needle thread Tension
- VI. Location and Regulation of the Machine
 - 1. Regulation of Symmetrical Positions of Horizontal
 - 2. Location of Rotating hook
 - 3. Height of Needle bar
 - 4. Mounting and Dismounting of Rotating shuttle
- VII. Faults Locating & How to Treat
- VIII. Modes of Sewing and Application of Accessories
 - 1. Linear Sewing
 - 2. Embroidery
 - 3. Zippered Sewing
 - 4. Hem-Wrapping mode
 - 5. Stem-wrapping mode
 - 6. Decoration Sewing
 - 7. Other modes of practical Sewing
- IX. Examples of Components

I. BRIEF INTRODUCTION OF THE MACHINE

Series products of Curved-stitching Sewing machine are multi-purposed, locked-type and crvred stitching mechanism for industrial embroidery.

This series of machines can be used in the trades of embroidery, garment, beddings, shoes and hats, gloves and leather pieces and suitcases and handbags. It can also be extensively applied to the material with thin or medium thickness for linear and curvilinear sewing.

The machine is designed as a structure which can be expected to stitch-up of prick with connecting- levers, to crochet with shuttles or differential gears, and provided with swaying needle- staff,clockwise can counter-clockwise units and kneeing device. The ma-chine features in smooth running, flexible operation, convenient maintenance as well as neat and beautiful stitches.

II. Main Technical Specifications and Application

Description			Curved-stitching	Double Curved-stitching
Max. Speed	Linear		2000 stitches/min	
	Curvilinear	Horizontal needle distance 1~5mm	1700 stitches/min	
		Horizontal needle distance 5~12mm	1200 stitches/min	
Max. Length of stitches	Linear		12mm	6mm(Swaying width of Single needle)
	Curvilinear	Left-needle Position		
		Central-needle Position		
Right-needle Position				
Distance. Between double stitches			—	2.5, 3.5, 4.5(Changeable)
Height of Presser foot	Hand stitch		no less than 6mm	
	Kneeing stitch		12mm	
Max. Thickness of sewing			No less than 8 layers	
Specification of needle			DPX5 (Nm700~130)	
Thread			No. 40~100 terylene and the like	
Dimension of machine head(L×W×H)			450×180×320mm	
Motor Power			0.37KW	
Application			For rough stitching, piece-together stitching, Loop stitching, Z-Shape stitching and decorating stitching	For double stitching and curved-stitches decorations

III. INSTALLATION AND PREPARATION FOR OPERATION

1. Installation

(1) Fixing of oil Disk

Fix the oil disk (1) with 4 pins (2) onto the frame openings of the plate. Make sure the distance between the oil disk and the plate surface is equal to 25mm. The right side of the oil disk should be kept in line with the right frame of the plate (see Figure 1).

(2) Installation of machine Head (see Figure 2)

In installation, the base of connecting hook (1) and the pad (2) should be firstly fastened firmly at a proper place with the metal nails when the 4 rubber pads (3) are being fixed. Make sure the metal nails should be embedded entirely into the rubber washer. Then the machine head can be installed on the plate with connecting hooks. Attention should be attached to flexible movement and the 4 angles being flat and stable.

(3) Installation of knee-control component

The installation of this component should be conducted according to the Figure 3, and much importance be attached to the flexibility of operation.

① The location of the knee-control block 1 ought to be adjusted in accordance with the operator's working condition to ensure convenience in operation.

② How to locate the adjuster 2: When adjuster 2 is aimed to control the movement of part 3 the knee component can be used to control the swaying of the needle. When the adjuster 2 is aimed to control the movement of part 4, the knee component can be used to control the upraising of presser foot.

(4) Installation of motor (see Figure 4)

① Turn the motor 1 from side to side in a bid to ensure the driving wheel of the sewing machine 3 being in line with the pulley of the motor 2.

② How to regulate the running direction: Viewed from the outside of the driving wheel, the running direction should be counter-clockwise. Make sure that the turning of the motor should be in uniform and regular direction which can be regulated by the power plug on the motor with change of 180°.

③ How to regulate the tension of O-shaped Belt 4.

Release the Nut 5, and turn the motor so that the Belt tension can be regulated. If press down the belt with your fingers and bend it over to 12-20 mm as shown in Figure 4, the tension is considered as ideal one.

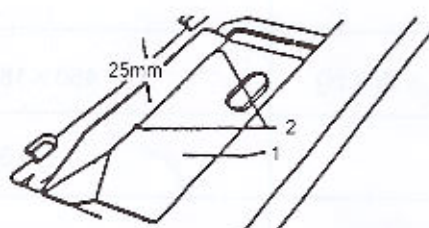

Figure 1

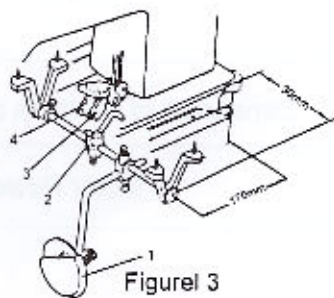

Figure 3

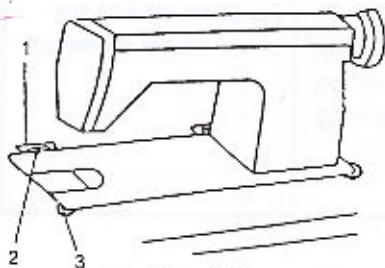

Figure 2

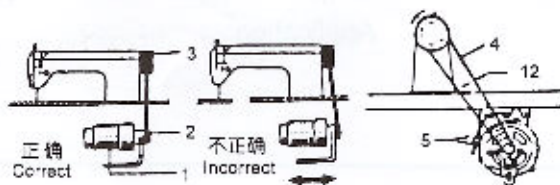

Figure 4

2. Preparation for Operation

(1) Cleaning the machine

Before shipping, every part of the machine head is intended to be coated with antirust grease in a bid to prevent the components from being rusted. After shipping, the applied grease might be hardened during the long-distance transportation or in storage, and particles and dust accumulated on the surface of the machine. And thus all the hardened grease, particles and dust should be wiped clean with gasoline and soft cloth.

(2) Installation

After leaving factory, the machine is possibly subject to violent vibration during the long distance transportation so that the components could be loosened or deformed. A close and comprehensive inspection is needed when all the oily stain has been wiped clean. Turn the driving wheel manually to see if there is any difficulty in truning of the components ,any bump or obstruction, or any abnormal sounds. If any, the affected components should be adjusted until the machine is capable of running regularly.

(3) Lubrication

After the machine being wiped clean with soft cloth but before operating, all the turning and movable parts and the oil holes in Figure 5 should be fully lubricated.

When the machine is needed to run continuously, lubrication should be made several time each day.

No 2 white lubricant of HJ-7 mechanical oil is preferentially used.

(4) Test run

When a new machine is operated at the first time or a machine is newly used after a long time of laying off, the machine should be made idle-running, What is more important at the moment is that the running direction of upper wheel should be counter-clockwise (viewed from the outside of the upper wheel)and the presser foot raised. At the beginning, the running should be at low speed, and could be gradually increaded to 2000r/m when it comes to normal state. A few

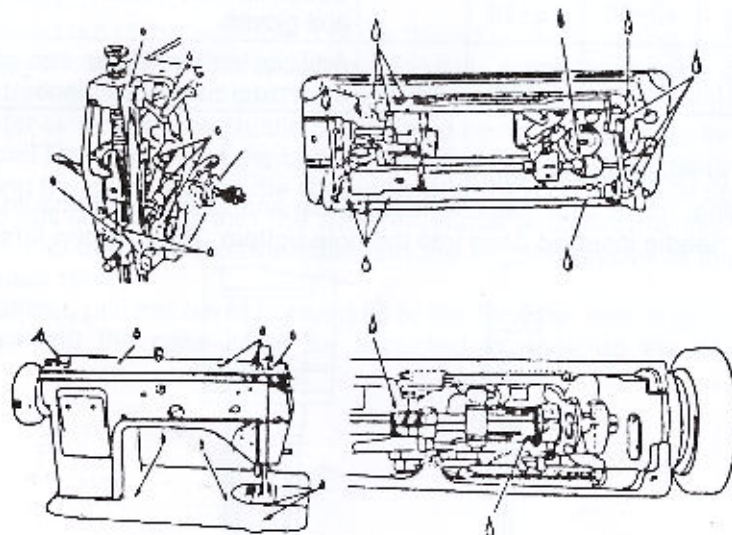

Figure 5

Minutes later, it is necessary to reexamine any sign of wear and tear about the components until the machine can be operated normally.

IV. HOW TO OPERATE

1. Selection of stitches

Left-handed rotation stitches can only be applied to the surface, while either left-handed or right-handed rotation stitches can be applied to the bottom.

The rotational direction of stitches can be identified according to the indication shown in Figure 6. Hold the stitch with both hands and then twist it by the right hand and in the direction as the arrow shows. If the more it twists, the tighter it becomes, undoubtedly it should be left-handed rotation stitch. Otherwise it is right-handed one.

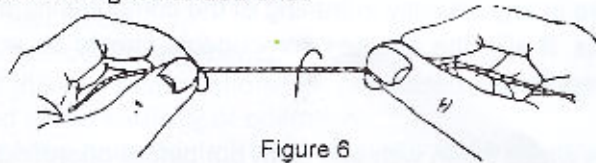

Figure 6

2. Coordination of Needle, Thread and material

DPX5 needle is chosen in preference. The number of needle can be selected in line with the material and thread used. (See the following Table)

Decent needles can be selected in accordance with the material listed in the above Table.

Needle Number	Number, Kind of thread			Kind of material
	Cotton	Silk	Nylon	
DPX5				
65~75(9#~11#)	80~150	240~30	3~56	Georgette, gunny, napkin, embroidered-Satin
75~90(11#~14#)	60~80			Khaki, woolen fabric embroidery
90~100(14#~16#)	40~60	16~18		Cotton flannel, woolen serge, embroidered satin and gloves
100~130(16#~22#)	30~40	21~60	10~40	Artificial leather, shoes and hats, suit-case embroidered leather-biece

3. Assemblage of Needle (see Figure 7)

When assembling, make sure that the needle hole and its long slot should face the operator with the rear part of needle inserted deep into the hole bottom. Then tighten firmly the set screw.

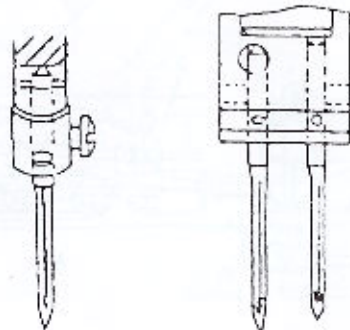

A

Figure 7

B

4. Winding thread around the shuttle core (see Figure 8)

(1) Hold the upper wheel with your left hand, and turn the on-off screw A in the direction of the operator, then release it;

(2) Get the shuttle core onto the axis of the winder B, and clamp it down to the full;

(3) Shown as the Figure, Let the thread run through the two holes C1, C2 on the upper thread-running plate and the thread-holding plate D; then the end of the thread is made to go around the shuttle core for several circles. In the case the thread-volume-adjusting plate E is clamped toward the shuttle core, operate the machine immediately;

(4) If the full thread around the shuttle core is found, it can be expected to stop winding automatically.

To regulate the winding volume of the shuttle core, a screwdriver can be used to secure the volume-regulating shaft G, and then loosen the screw F and turn the pressing plate E, If more winding volume is needed, the pressing plate is made to go against the operator and vice versa. In general, the volume can be set to less than 0.5~1mm of the external diameter of the shuttle core, then secure the screw F.

The thread around the shuttle core should be arranged neat and compact, If too Loose or relax, the pressure of thread-holding plate should be strengthened by turning the nut; If being in uneven arrangement, release the set screw H, and adjust the component of the upper thread-running plate 1 until the thread arrangement is satisfactory, and then fix it.

During sewing, automatic winding of thread can be effected in line with a proper procedure but not to release the on-off screw A.

5. Threading surface and Bottom stitches

When threading the surface stitches, the needle staff should be at the top position. The end is led from the thread rack, curved stitchings are made to run through 1-13 as shown in Figure 9a and then through the needle hole 12, meanwhile a length of 100mm should be drawn out for spare Thread. The threading surface stitches of double curvea stitches should be made as shown in Figure 9b.

When threading the bottom stitches, firstly hold the end of surface stitch, then turn the driving wheel to make the needle staff run downward and immediately back to the top position. Pull up the end of surface stitch, resulting in drawing the bottom stitch upward. Finally, both ends of the surface stitch and the bottom stitch are set to the front of presser foot altogether.

6. Mounting of shuttle core (see Figure 10)

(1) Mount the shuttle core onto the case and pull out the thread from the long slot ① and thread-pressing spring ②.

(2) Pull the thread out of the end-hole 3 of the thread pressing spring;

(3) Run the thread through the thread-conveying hole 4 and leave aside the end about 60mm.

Note: When drawing the thread end, it s normal for the shuttle core to turn clockwise; If not in this case (or counter clockwise) the shuttle core should be remounted after turning over its side.

7. Mounting and Dismounting of the case (of the shuttle core) (see Figure 11)

When mounting the case, the needle should be at the top position. Pull apart the front cover 1 of the shuttle and set the case 3 into the rotation shuttle according to the indication shown in Figure 11, but it should be noted that the case and the locating groove of the shuttle shaft could be engaged in a good state.

When dismounting, pull the cover outward till to the full stop, then it firmly and gradually take down the case so that the case could be expected to hook up the core which won t be disengaged.

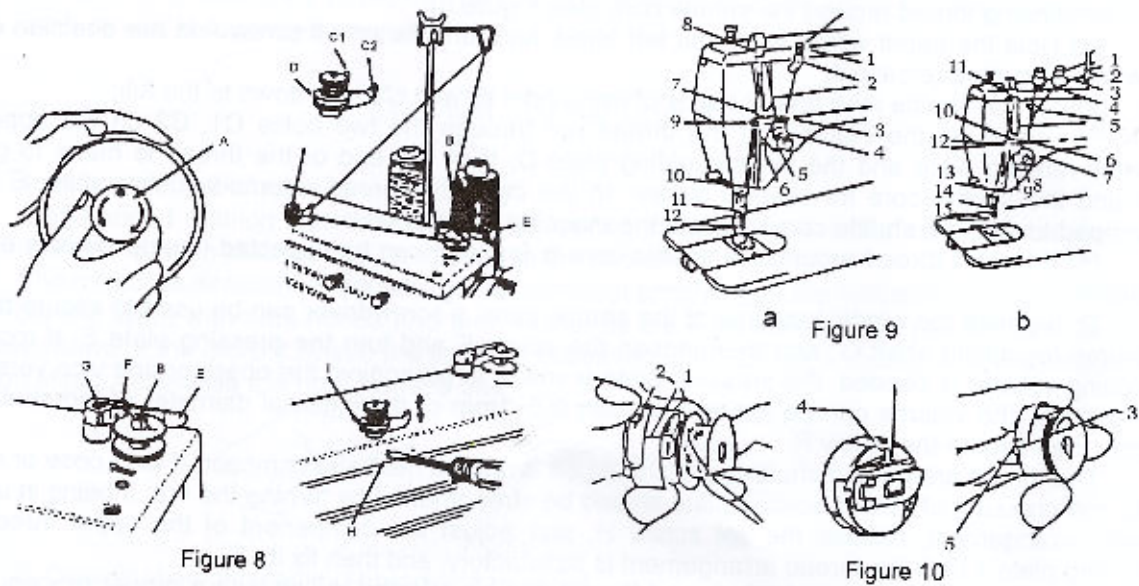

Figure 8

a Figure 9

b

Figure 10

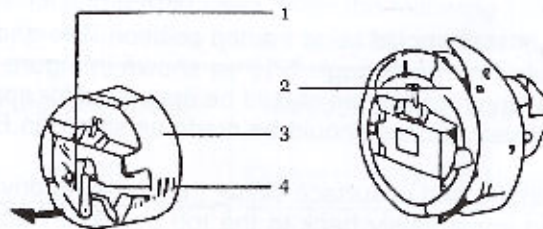

Figure 11

8. Adjustment of material-feeding

Adjustment of vertical needle distance (see Figure 12)

(1) The vertical needle distance can be reduced by turning the knob B clockwise.

(2) The distance can be increased by turning the knob B counter-clockwise.

The scale on the knob B is designed only for reference, which is not an exact value.

Adjustment of material-feeding

(1) When the handle A is found in a free state, the material-feeding can be considered in a direct motion.

(2) But when the Handle A is pressed down to the lowest position, the material-feeding can be considered in reverse motion.

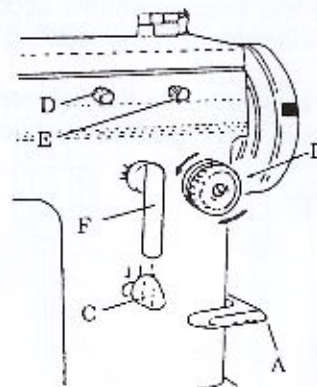

Figure 12

9. Adjustment of the pressure of presser foot

On the condition that the material-feeding can be conducted directly and regularly, the pressure of the presser foot should be a moderate one rather than a big one. In general, the pressure should be increased on sewing the thick material. If on sewing the thin material, the pressure reduced. Shown as the Figure 13, turn the nut for adjusting pressure clockwise and the pressure tends to go up, while turn the nut counter-clockwise, and the pressure down.

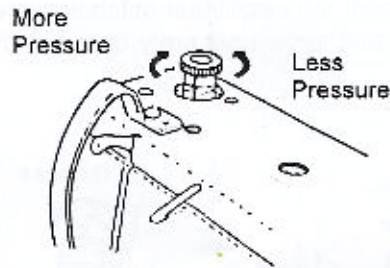

Figure 13

10. Selection of needle position

The three positions, left, central and right, are suitable for both the linear stitching and the curvilinear one.

The central position can be expected to suit for conventional sewing. Only when a particular sewing is needed, can the needle be set to the left or right position.

Seen in the Figure 12, if the single-sided curved handle C is set to the predicted position, the proper stitchings can be effected (also see Figure 14)

11. Adjustment of horizontal needle distance (see Figure 12)

(1) If any one fixed value between 0~12mm of curvilinear stitchings is needed, the adjustment can be made as follows;

- Release the horizontal needle set screws D, E;
- Turn the spanner F clockwise to a position needed;
- Lock the screws D, E;

(2) On sewing when a variation of any one fixed area between 0~12mm of curvilinear stitchings is needed (For example 2~8mm), the adjustment can be made as follows:

a. Loosen the set screw D (for control of the narrow curvilinear one) and F (for control of the wide curvilinear one);

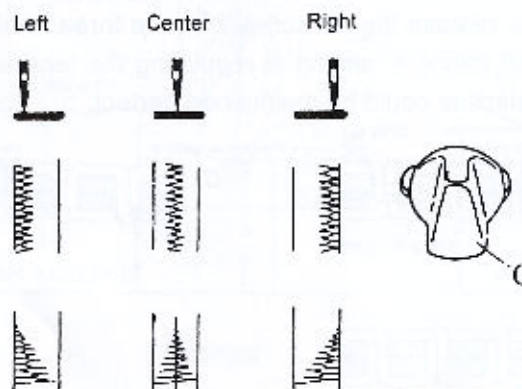

Figure 14

b. Set the spanner to the position of 2mm and lock the screw E.

In this way, the horizontal needle distance can be changed from 2mm (the narrow one) and 8mm (the wide one) randomly.

12. Locking unit for linear stitching (see Figure 15)

When the horizontal needle distance is set to position for Linear stitching, turn the linear and Locking eccentric sleeve A clockwise, secure the needle-bar swaying rack and then the effect of the linear stitching will be better. When the curvilinear stitchings are made, the eccentric sleeve A should be turned counter-clockwise and locked securely onto the machine housing, then release the swaying rack of the needle bar.

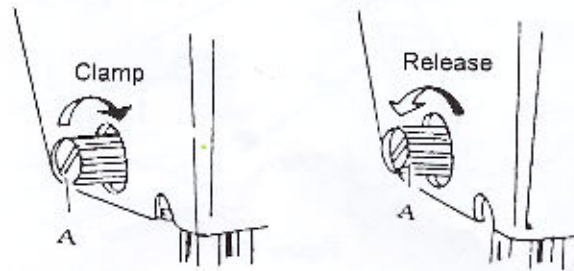

Figure 15

V. TENSION OF STITCHES

Adjust the tension of surface stitches and of the bottom stitches to the best extent (see Figure 16) so that the coil of surface stitches and of the bottom stitches could be locked between the two layers of material, and all the stitchings should not be too tight nor too loose with the material to be sewn increased.

1. Adjustment of Bottom stitch Tension

In the light of indication shown in Figure 17, turn the screw 1 for adjusting the tension of bottom stitches. Hold the end in your hand and suspend the case of shuttle core upward. Then the case will slide down on its own weight, which shows that the tension of bottom stitches has reached the best extent.

2. Adjustment of the surface stitch Tension

In the light of indication shown in Figure 18, turn the nuts for adjusting the tension of the surface stitches. Alternatively, release the set screw 2 on the thread-holder, then turn screw 3 for adjusting the position of stitch spring 4, aiming at regulating the tension of surface stitches. As a result, the width of bottom stitches could be maintained perfect.

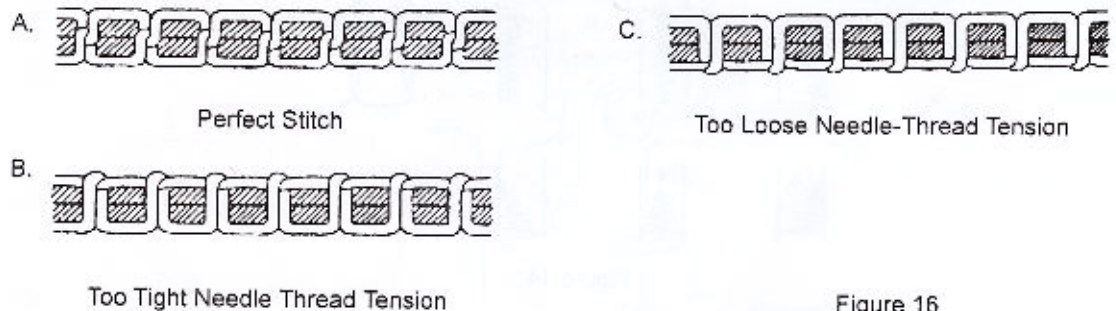

Figure 16

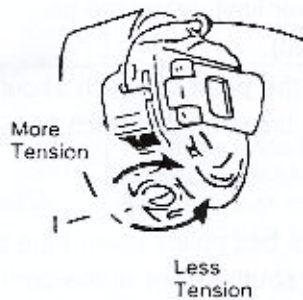

Figure 17

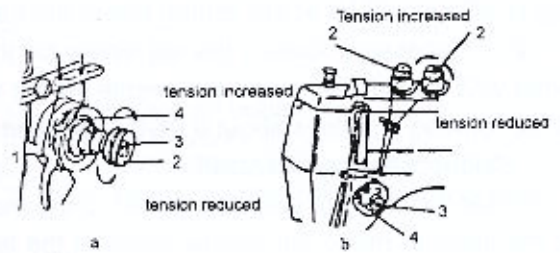

Figure 18

VI. LOCATION AND REGULATION OF THE MACHINE

1. Regulation of symmetrical position of horizontal stitches

As shown in Figure 19. When the height of the left and right movement during the needle travelling is not the same, either at the beginning or in the end, skipping will be found and the embroidery material might tear by the needle. In this way no good embroidery could be produced.

In order that the correct and coordinate position of movement could be achieved, the following steps should be taken; remove the upper cover, release the set screw on the gear of upper shaft and then slightly turn the gear to observe the stitches and adjust the movement of the needle up-till to the coordinated position, at length tighten the set screw.

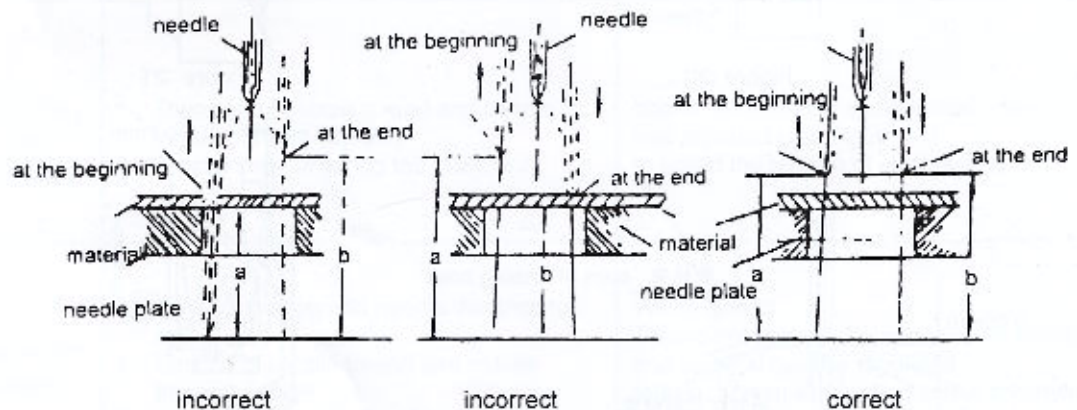

2. location of rotating shuttle

(1) Manually so to raise the needle (In case of double curvilinear stitches, the needle is referred to the one on the right side, The same below) by 2.2mm from the lower limit, when the point of rotating shuttle would be at the central line of the needle. (See Figure 20)

(2) If necessary, loosen the set screw on the rotating shuttle, the point of which should be aligned with the central line of the needle. At the moment, the space between the notch of needle and the rotating shuttle is about 0.05-0.1mm (see Figure 21).

3. Height of the needle staff

(1) Set the width of swaying needle to the maximum and turn the belt pulley toward the operator manually to make the needle stand at the left position and the shuttle point at the centre of the needle. At the moment the length from the needle hole till the shuttle point should be 0~0.5mm (see Figure 22)

(2) If the height of needle staff is not in the correct position, it is necessary to remove the panel, release the connecting screw on the needle staff, and then raise or lower the staff to the standard height. After that, re-tighten the screw.

4. Mounting and Dismounting of Rotating shuttle (see Figure 23)

To start with, raise the needle staff to the maximum before removing the rotating shuttle, then remove needle plate, needle and the case of shuttle core, meanwhile take down the screw 1 on the locating hook for the rotating shuttle and the locating hook 3 itself; release the three screws on the shuttle, which is capable of rotating freely along the driving spindle, Turn the upper wheel manually to make the feeding rack go upward. At this point, turn the rotating shuttle manually to allow the feeding rack passing by the position to be touched and then remove it.

The mounting of shuttle is done in an inverted order with the process of dismounting.

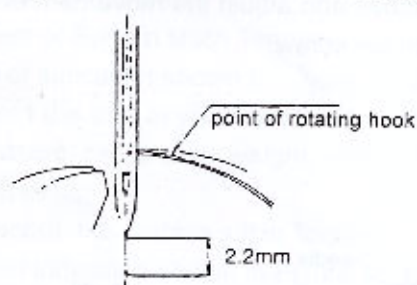

Figure 20

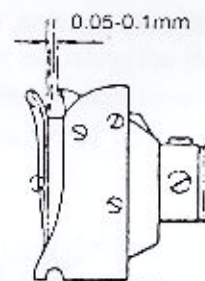

Figure 21

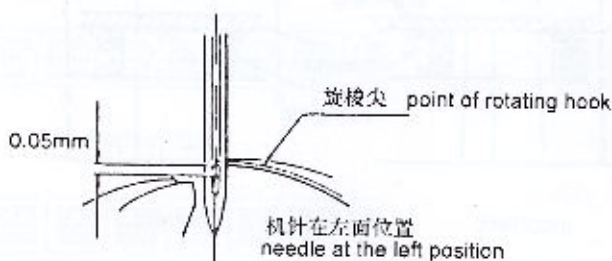

Figure 22

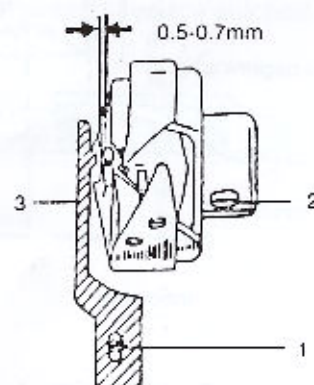

Figure 23

VII. FAULTS LOCATING AND HOW TO TREAT

Type	Cause of Fault	How to treat
Needle is broken	<ol style="list-style-type: none"> 1. needle is too fine or bent 2. installation of needle not correct 3. to pull-push manually during sewing 4. material too solid or too thick 	replace the needle see Figure 7. Slightly adjust, don't pull-push manually material selected in line with specification
Skipping	<ol style="list-style-type: none"> 1. needle is bent or it's thickness is not matched with the material 2. installation of needle not correct 	replace the needle see Figure 7.
Needle thread broken	<ol style="list-style-type: none"> 1. threading is incorrect 2. needle thread too tight 3. poor quality of thread 4. needle too fine or needle thread too rough 	see Figure 9 tension of needle thread should be reduced (see Figure 18) replace the thread replace the needle
Bobbin thread broken	<ol style="list-style-type: none"> 1. The needle thread too tight 2. the thread-winding looes or uneven 3. hole of needle plate rough or worn out 	tension of bobbin thread reduced re-winding the thread replace needle plate or to smooth the hole with emery cloth
Stitches are loosened	<ol style="list-style-type: none"> 1. Thension of bobbin thread and needle thread not well-adjusted 2. Thread take-up spring too loosened 	bobbin thread and needle thread should be well adjusted (see Figure 18) to adjust the tension of stitch-spring
Material gets Creased	<ol style="list-style-type: none"> 1. material too thin and needle distance too big 2. Tension of bobbin thread and needle thread too high 3. pressure of presser foot high 	Well-adjusted Thread-holding nut, Thread take-up spring and screw should be regulated release pressure-adjusting screw and reduce the pressure of presser foot

VIII. MODES OF SEWING AND APPLICATION OF ACCESSORIES

1. Linear Sewing

In case of linear sewing, the best effect and wider scope of application will be achieved if adoption of the special linear presser foot, needle plate and material-feeding tooth (see Figure 24) rather than the multi-functional ones.

During linear sewing, the horizontal needle distance should be set to O position, and the lin locking unit with swaying rack of locking needle shaft can be used in combination with special presser foot, needle plate and material-feeding tooth. To replace material-feeding tooth, firstly move needle plate and its inner cover, then push the thrust plate outward, release two screws and replace the multi-functional material-feeding tooth with the special one.

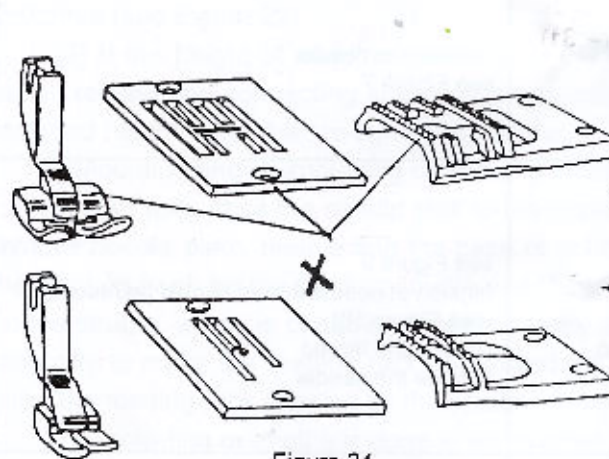

Figure 24

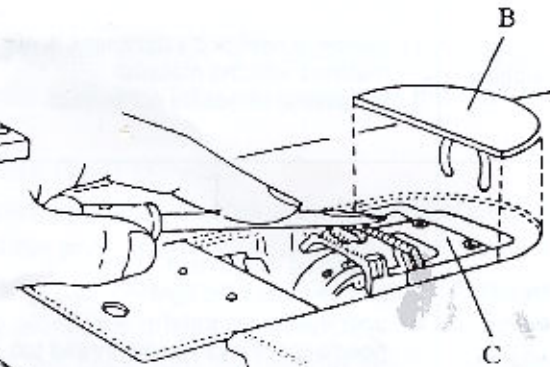

Figure 25

2. Embroidery

Preparation before embroidering

(1) It should be noted that and free regulation can be made at the horizontal needle distance between 0-12mm. Set the vertical needle distance to O position and will adjust the knee-con parts (see Figure 3) to make the component 2 control the movement of the component 3. As a result, the 'knee' can be predicted to control the swaying of the needle;

(2) Remove the presser foot, needle plate, inner cover, thrust plate and material-feeding tooth. After that, the embroidering plate is put into use;

(3) Hold firmly the end of the surface stitches with your left hand, turn the belt pulley manually toward the operator, and then makes the bottom stitches pull out from the holes of the needle plate;

(4) Make sure to stretch tightly the material between the internal and external embroidering frame. Otherwise, skipping, stitches-breaking or material creased might be found (see Figure 26);

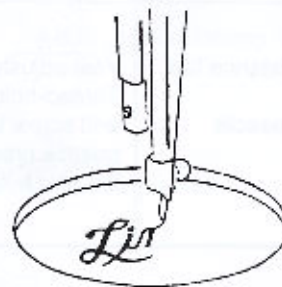

Figure 26

3. Zippered Sewing

This mode is preferable to make use of zippered presser foot (see Figure 27) in a bid to make the stitches more accessible to the projecting stitches. Then release the screw B, regulate the presser foot and set the needle to the presser foot and set the needle to the left and right grooves A of the presser foot. This mode is expected to suit the sewings, seen in the Figure 28.

4. Hem-wrapping mode

In this mode, the hem-wrapping presser foot can be used as we wish (see Figure 29). Remove the multi-functional presser foot and replace it with the hem-wrapping one. This is also a mode of linear sewing with the needle set to the central position, shown as in the Figure 30, the hem-wrapping operation can be effected.

5. Stem-wrapping mode

During the sewing with the stem-wrapping mode, the special stem-wrapping presser foot, needle plate and material-feeding tooth (see Figure 31) should be put into use. The needle is set to the central position and the horizontal needle distance set to 3mm, and then run the rougher thread through the small groove A on the stem-wrapping presser foot so that the sewing of this mode will be smoothly conducted (see Figure 32).

6. Decoration Sewing

If the left, central and right needle positions can be freely changeable and the horizontal needle distance skillfully controlled, the patterns of the decoration sewing will be well achieved as seen in the Figure 33.

7. Other modes of practical sewing (see Figure 34)

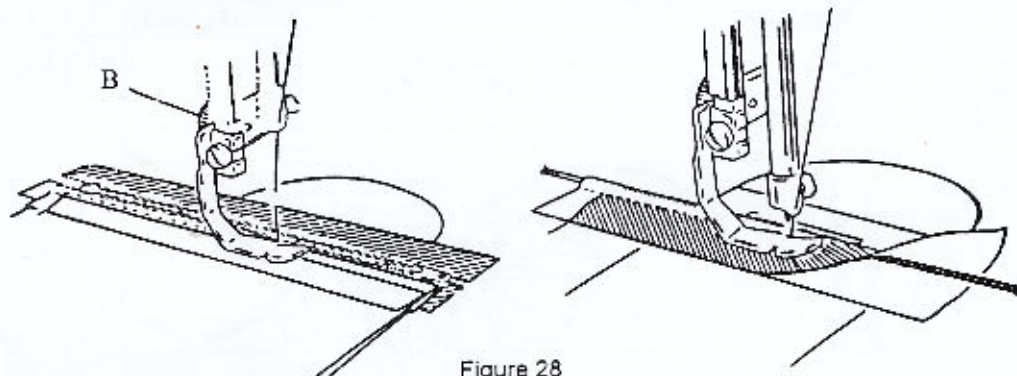

Figure 28

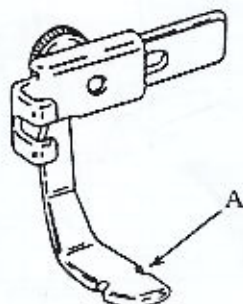

Figure 27

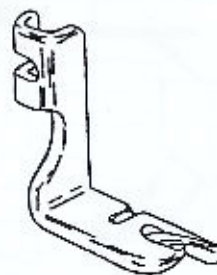

Figure 29

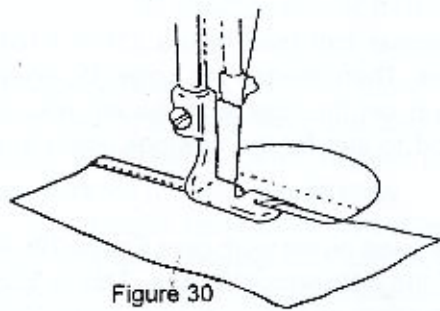

Figure 30

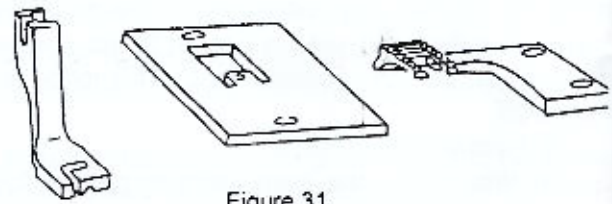

Figure 31

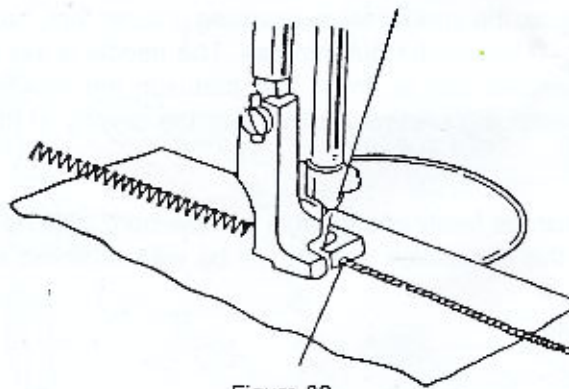

Figure 32



Figure 33



Button hole

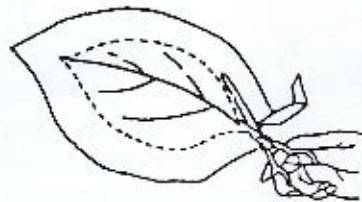

Lotus-leaves Embroidery

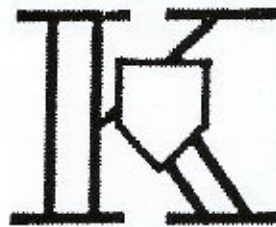

Word-Embroidery

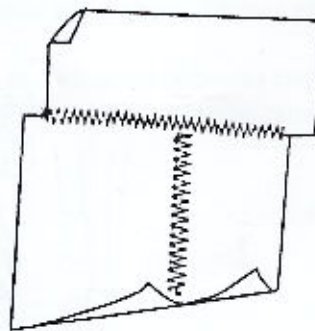

Piecing-together Sewing

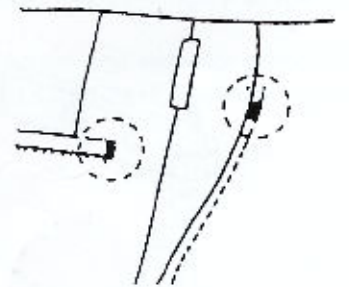

Looping Sewing

IX. COMPONENT EXAMPLE

1. Components of housing

Seri No.	Code No.	Description	Products applicable			
			Curved-stitching	Qty	Double Curved-stitching	Qty
1	U43T1-0	Housing	✓	1	✓	1
2	U43T1-1-3	Model-plate	✓	1	✓	
3	U43T1-1-7	Model-plate river	✓	2	✓	2
4	U43T1-1-8	Model-plate			✓	1
5	U43T1-2-1	Face plate	✓	1	✓	1
6	U43T1-2-3	Face plate thread guide	✓	1	✓	1
7	U43T1-2-2	thread guide screw	✓	1	✓	1
8	U43T1-2-3	thread guide nut	✓	2	✓	2
9	U43T1-3	Face Plate screw	✓	2	✓	2
10	U43T1-4	Linear lock eccentric screw	✓	1	✓	1
11	U43T1-5	Linear lock eccentric	✓	1	✓	1
12	U43T1-6-1	Thrust plate	✓	1	✓	1
13	U43T1-6-2	Thrust plate spring	✓	1	✓	1
14	U43T1-6-3	Thrust plate spring screw	✓	2	✓	2
15	U43T1-7	Needle plate	✓	1	✓	1
16	U43T1-8	Needle plate screw	✓	2	✓	2
17	U43T1-9-1	Inner cover plate	✓	1	✓	1
18	U43T1-9-2	Cover plate spring	✓	1	✓	1
19	U43T1-9-3	Cover plate spring Screw	✓	2	✓	2
20	U43T1-10	Thread take up lever shield	✓	1	✓	1
21	U43T1-11	Shield screw	✓	1	✓	1
22	U43T1-12	Washer	✓	1	✓	1
23	U43T1-13	Rotating hook shield	✓	1		1
24	U43T1-14	Rotating hook shield screw	✓	1		
25	U43T1-15	Thread-releasing lever	✓	1		
26	U43T1-16	Thread-releasing lever spring	✓	1		
27	U43T1-17	Thread-releasing lever screw	✓	1	✓	1
28	U43T1-18	Lower thread-running pin	✓	1		
29	U43T1-19	Double thread-running rack	✓	1	✓	1
30	U43T1-20	Thread-running rack screw	✓	1	✓	1
31	U43T1-21	Thread-releasing pin	✓	1	✓	1
32	U43T1-22	Thread-hold fixing screw	✓	1	✓	1
33	U43T1-19a	Thread-running rack		1		
34	U43T1-23-1	Thread Tension regulator bushing	✓	1		1
35	U43T1-23-2	Fixing screw	✓	1	✓	
36	U43T1-23-3	Thread take-up spring	✓	1		
37	U43T1-23-4	Thread tension stud	✓	1		
38	U43T1-23-5	Thread tension disc	✓	2		
39	U43T1-23-6	Thread tension-releasing disc	✓	1		
40	U43T1-23-7	Thread tension spring	✓	1		
41	U43T1-23-8	Thumb nut revolution stopper	✓	1	✓	1
42	U43T1-23-9	Thumb nut	✓	1	✓	1

Seri No.	Code No.	Description	Products applicable			
			Curved-stitching	Qty	Double Curved-stitching	Qty
43	U43T1-24	Upper cover	✓	1		
44	U43T1-25	Upper cover back screw	✓	1	✓	1
45	U43T1-26	3-eyelet hole thread guide	✓	1	✓	1
46	U43T1-27	3-eyelet hole thread guide screw	✓	1	✓	1
47	U43T1-28	Rubber plug(big)	✓	1	✓	1
48	U43T1-29	Rubber plug(medinm)	✓	1	✓	1
49	U43T1-30	Rubber plug(small)	✓	1	✓	1
50	U43T1-31	Upper cover set screw	✓	2	✓	2
51	U43T1-32	Fastening screw	✓	1	✓	1
52	U43T1-33-0	Upper thread-guide component	✓	1	✓	1
53	U43T1-33-1	Thread-guide			✓	1
54	U43T1-33-2	Thread-tension stud			✓	1
55	U43T1-33-3	Upper thread-tension disc	✓	2	✓	2
56	U43T1-33-4	Upper thread-tension spring	✓	1	✓	1
57	U43T1-33-5	Nut	✓	2	✓	1
58	U43T1-34	Back cover	✓	4	✓	4
59	U43T1-35	Back cover screw	✓	1	✓	1
60	U43T1-37	locating block set screw	✓	1	✓	1
61	U43T1-37-1	Locating block	✓	1	✓	1
62	U43T1-38	Volume-adjusting spindle	✓	1	✓	1
63	U43T1-39	Washer	✓	1	✓	1
64	U43T1-40	Pressing plate screw	✓	1	✓	1
65	U43T1-41	Volume-adjusting plate	✓	1	✓	1
66	U43T1-42	Extension spring pin	✓	1	✓	1
67	U43T1-43	Extension spring	✓	1	✓	1
68	U43T1-44	Crank screw	✓	1	✓	1
69	U43T1-45	Thread-winding swaying handle	✓	1	✓	1
70	U43T1-46	Swaying handle presser spring	✓	1	✓	1
71	U43T1-47	Axis	✓	1	✓	1
72	U43T1-48	Thread-winding small wheel	✓	1	✓	1
73	U43T1-49	Thread-winding rull wheel	✓	1	✓	1
74	U43T1-50	Thread-winding axis spring	✓	1	✓	1
75	U43T1-51	Thread-winding crank	✓	1	✓	1
76	U43T1-52	Thrum Nut			✓	2
77	U43T1-53	Thrum Nut revolution stopper			✓	2
78	U43T1-54	Thread-tension spring			✓	2
79	U43T1-55	Thread-tension cover base			✓	2
80	U43T1-56	Thread-tension cover base			✓	4
81	U43T1-57	Uppere cover			✓	1
82	U43T1-58	Thread tension regulator bushing			✓	1
83	U43T1-59	Thread take up spring			✓	1
84	U43T1-60	Thread take up spring screw			✓	1
85	U43T1-61	Guide component			✓	1

1. Components of housing

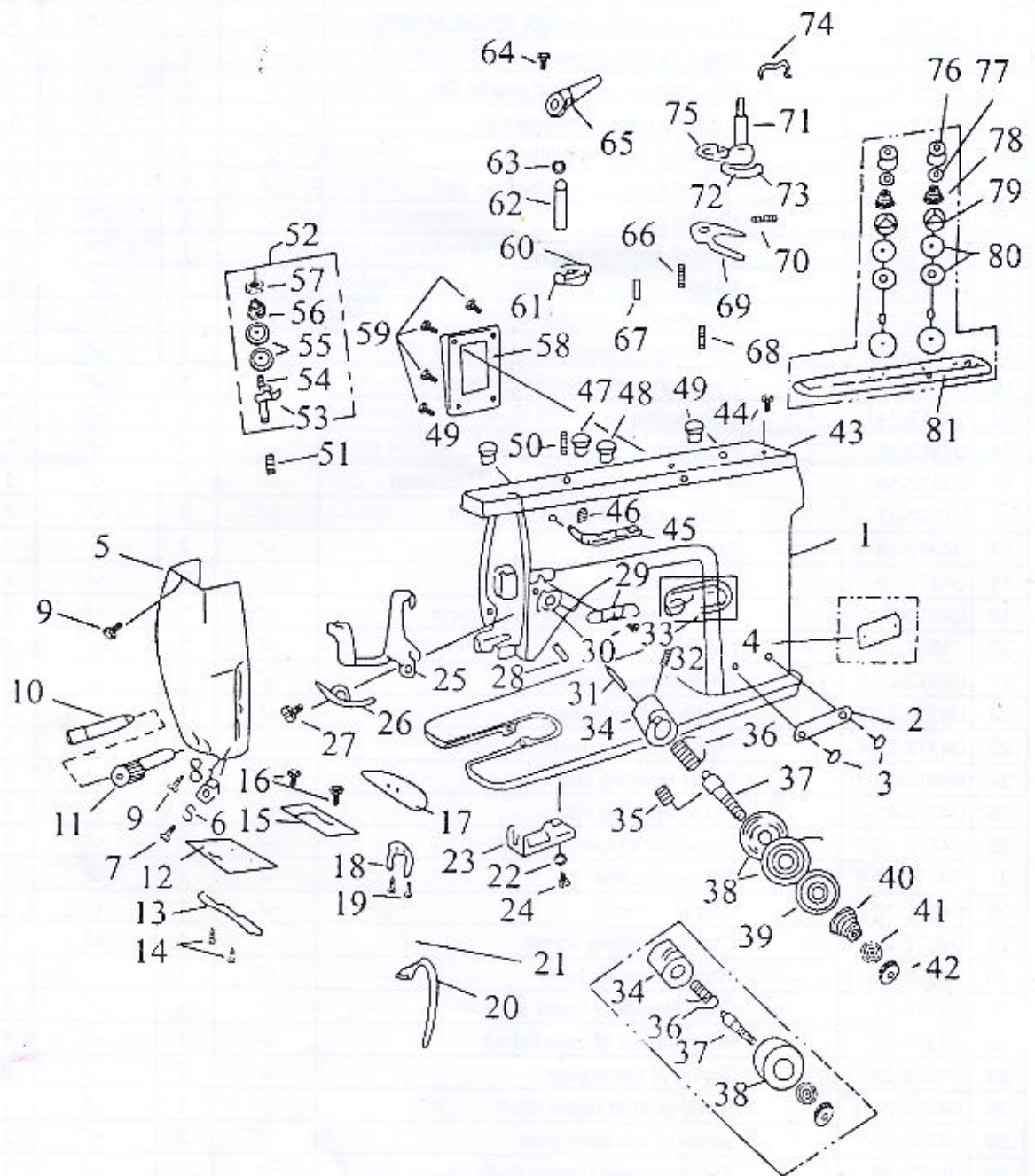

2、 Thread take-up and needle bar components

Seri No.	Code No.	Description	Products applicable			
			Curved-stitching	Qty	Double Curved-stitching	Qty
1	U43T2-2	Pin screw(swaying rack of needle staff)	✓	1	✓	1
2	U43T2-3	Swaying rack of needle bar	✓	1		
3	U43T2-4	Eccentric pin screw of needle bar	✓	1	✓	1
4	U43T2-5	Locating plate of needle bar	✓	1	✓	1
5	U43T2-6	Screw of locating plate	✓	1	✓	1
6	U43T2-7	Ping of swaying rack(needle bar)	✓	1	✓	1
7	U43T2-8	Needle bar	✓	1		
8	U43T2-9	Thread-guide of needle bar	✓	1		
9	U43T2-10	Needle	✓	1	✓	2
10	U43T2-11	Locking screw of needle	✓	1		
11	U43T2-12	Pin-screw of connecting shaft	✓	1	✓	1
12	U43T2-13	Pin-washer of connecting shaft	✓	1	✓	1
13	U43T2-14	Connecting shaft	✓	1	✓	1
14	U43T2-15	Pin of connecting shaft	✓	1	✓	1
15	U43T2-16	Pin-locking screw of connecting shaft	✓	1	✓	1
16	U43T2-17	Guide of small connecting staff	✓	1	✓	1
17	U43T2-18	Screw of guide	✓	2	✓	2
18	U43T2-19	Guide washer	✓	2	✓	2
19	U43T2-20-0	Thread take-up lever component	✓	1	✓	1
20	U43T2-20-1	Left-spiral screw	✓	1	✓	1
21	U43T2-20-2	Small connecting staff	✓	1	✓	1
22	U43T2-20-3	Crank of needle bar	✓	1	✓	1
23	U43T2-20-4	Thread take-up lever component			✓	1
24	U43T2-20-5	Stitch-swaying staff	✓	1	✓	1
25	U43T2-20-6	Pin of swaying staff	✓	1	✓	1
26	U43T2-20-7	Pin screw of swaying staff	✓	1	✓	1
27	U43T2-20-8	Screw of crank	✓	1	✓	1
28	U43T2-20-9	Crank	✓	1	✓	1
29	U43T2-20-10	Crank fastening screw	✓	1	✓	1
30	U43T2-20-11	Thread take-up lever	✓	1		
31	U43T2-21	Front sleeve of upper shaft	✓	1	✓	1
32	U43T2-22	Front sleeve of upper shaft	✓	1	✓	1
33	U43T2-23	Screw of spiral gear	✓	2	✓	2
34	U43T2-24	Spiral gear of upper shaft	✓	1	✓	1
35	U43T2-25	screw of arc-cone gear	✓	2	✓	2
36	U43T2-26	Arc-cone gear (upper shaft)	✓	1	✓	1
37	U43T2-27	Screw of feed cam	✓	2	✓	2
38	U43T2-28	Feed cam	✓	1	✓	1
39	U43T2-29	Upper shaft	✓	1	✓	1

Seri No.	Code No.	Description	Products applicable			
			Curved-stitching	Qty	Double Curved-stitching	Qty
40	U43T2-30	Back sleeve of upper shaft	✓	1	✓	1
41	U43T2-31	Fastening screw of back sleeve	✓	1	✓	1
42	U43T2-32	Sleeve of balance wheel	✓	1	✓	1
43	U43T2-33	Sleeve screw	✓	1	✓	1
44	U43T2-34	Balance wheel	✓	1	✓	1
45	U43T2-35	Clutch waher	✓	1	✓	1
46	U43T2-36	Clutch screw	✓	1	✓	1
47	U43T2-37	Small clutch screw	✓	1	✓	1
48	U43T2-39	Swaying rack of needle bar			✓	1
49	U43T2-40	Needle har for double needle			✓	1
50	U43T2-41	Fastening screw of double needle clamper			✓	1
51	U43T2-42	Double needle clamper (2.5mm)			✓	1
52	U43T2-43	Double needle clamper (3.5mm)			✓	1
53	U43T2-44	Double needle clamper (4.5mm)			✓	1
54	U43T2-45	Fastening screw			✓	2

2. Thread take-up and needle bar components

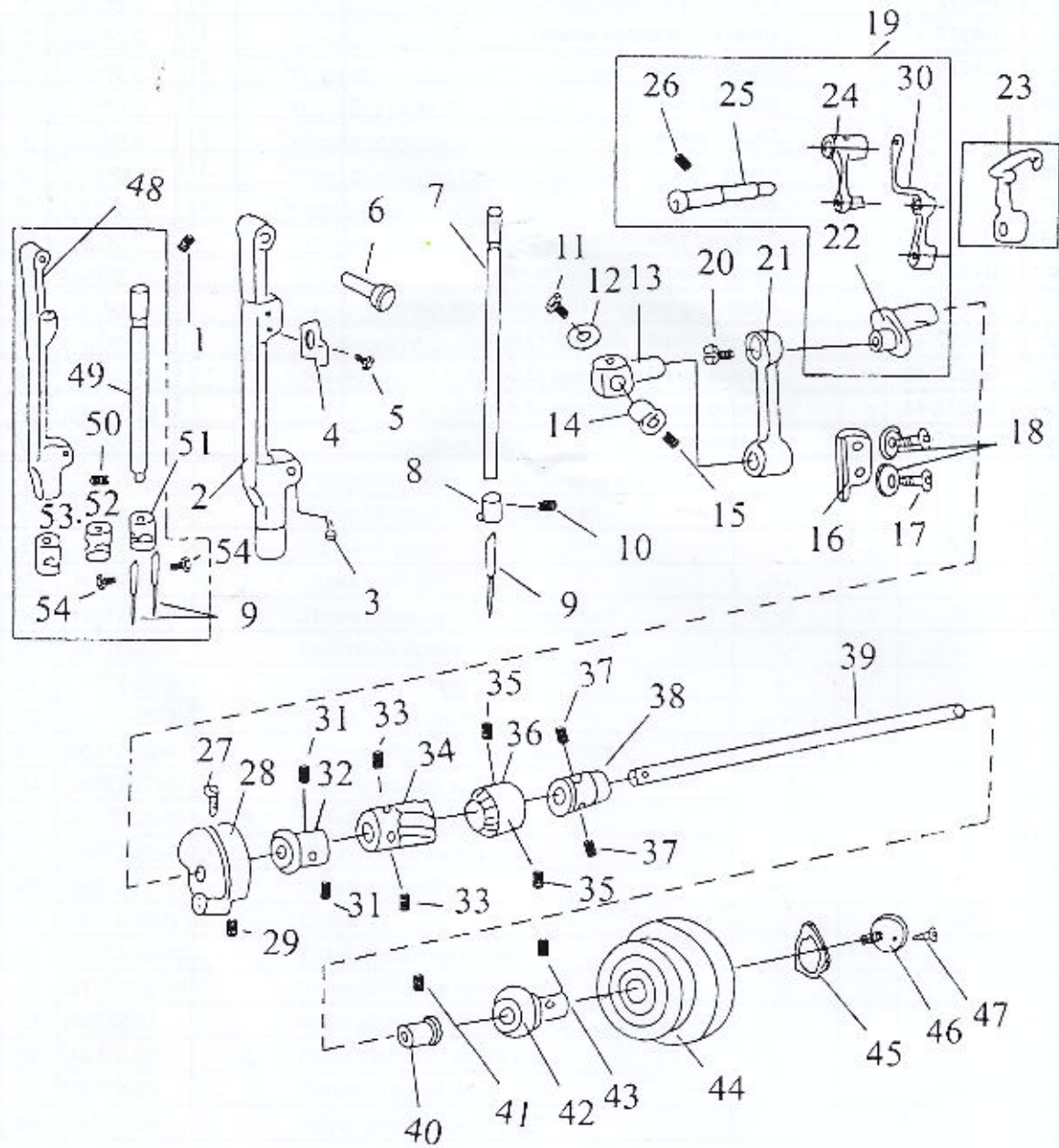

3. Material-feeding components

Seri No.	Code No.	Description	Products applicable			
			Curved-stitching	Qty	Double Curved-stitching	Qty
1	U43T3-1	Oil felt	✓	1	✓	1
2	U43T3-2	Lift feed connecting bar	✓	1	✓	1
3	U43T3-4	Small cone nut	✓	4	✓	4
4	U43T3-5	Connecting bar of needle distance base	✓	1	✓	1
5	U43T3-6	Small cone screw	✓	4	✓	4
6	U43T3-7	Pointed screw	✓	4	✓	4
7	U43T3-8	Pointed nut	✓	4	✓	4
8	U43T3-9	Feed crank	✓	1	✓	1
9	U43T3-10	Feed crank screw	✓	1	✓	1
10	U43T3-11	Feed crank screw	✓	2	✓	2
11	U43T3-12	Feed dog	✓	1	✓	1
12	U43T3-13	Pointed screw of tooth rack	✓	2	✓	2
13	U43T3-14	Point nut	✓	2	✓	2
14	U43T3-15	Feed rock	✓	1	✓	1
15	U43T3-16	Tooth rack	✓	1	✓	1
16	U43T3-17	Feed lifting rock shaft component	✓	1	✓	1
17	U43T3-18	Feed lifting rock crank screw	✓	1	✓	1
18	U43T3-19	Feed lifting rock crank	✓	1	✓	1
19	U43T3-20	Feed fork connecting rod	✓	1	✓	1

3. Materiml-feeding components

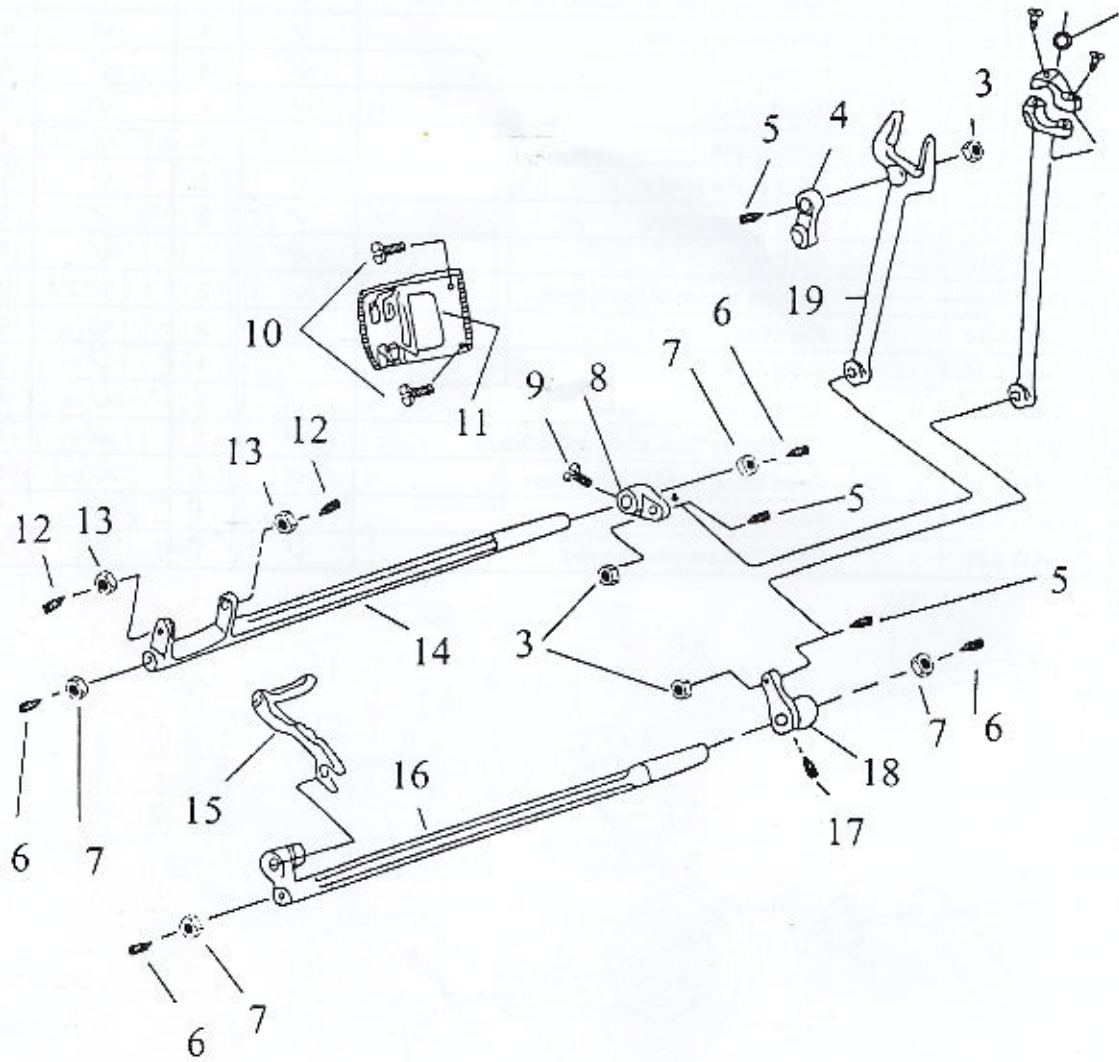

4、 Thread-hooking Components

Seri No.	Code No.	Description	Products applicable			
			Curved-stitching	Qty	Double Curved-stitching	Qty
1	U43T4-1	Locating plate of rotating hook	✓	1	✓	1
2	U43T4-2	Screw of locating plate	✓	1	✓	1
3	U43T4-3	Bobbin case	✓	1	✓	1
4	U43T4-4	Bobbin	✓	1	✓	1
5	U43T4-5	Rotating hook	✓	1	✓	1
6	U43T4-6	Front sleeve of rotating hook shaft	✓	1	✓	1
7	U43T4-7	Front sleeve screw	✓	1	✓	1
8	U43T4-8	Retainer of rotating hook shaft	✓	2	✓	2
9	U43T4-9	Retainer screw	✓	4	✓	4
10	U43T4-10	Back sleeve of rotating hook shaft	✓	1	✓	1
11	U43T4-11	Screw of back sleeve	✓	1	✓	1
12	U43T4-12	Rotating hook shaft	✓	1	✓	1
13	U43T4-13	Screw of arc-cone gear	✓	2	✓	2
14	U43T4-14	Arc-cone gear of rotating hook shaft		1		1
15	U43T4-15	Arc-cone gear of lower shaft	✓	1	✓	1
16	U43T4-16	Screw of Arc-cone gear	✓	2	✓	2
17	U43T4-17	Screw	✓	2	✓	2
18	U43T4-18	Front sleeve of lower shaft	✓	1	✓	1
19	U43T4-19	Lower shaft retainer	✓	3	✓	3
20	U43T4-20	Retainer screw of lower shaft	✓	6	✓	6
21	U43T4-21	Back sleeve of lower shaft	✓	1	✓	1
22	U43T4-22	Lower shaft	✓	1	✓	1
23	U43T4-23	Screw of differential gear(lower shaft)		2		2
24	U43T4-24	Differential gear	✓	1	✓	1
25	U43T4-25	Screw of differential gear	✓	2	✓	2
26	U43T4-26	Differential gear(vertical shaft)	✓	1	✓	1
27	U43T4-27	Lower sleeve of vertical shaft	✓	1	✓	1
28	U43T4-28	Differential shaft sliding-sleeve	✓	1	✓	1
29	U43T4-29	Lower clutch sleeve	✓	1	✓	1
30	U43T4-30	Screw	✓	2	✓	2
31	U43T4-31	Upper sleeve of vertical shaft	✓	1	✓	1
32	U43T4-32	Screw	✓	2	✓	2
33	U43T4-33	Upper sleeve of vertical shaft	✓	1	✓	1
34	U43T4-34	Screw of upper sleeve	✓	1	✓	1
35	U43T4-35	Arc-cone gear	✓	1	✓	1
36	U43T4-36	Differential connecting bar	✓	1	✓	1
37	U43T4-37	Vertical shaft	✓	1	✓	1

4. Thread-hooking Components

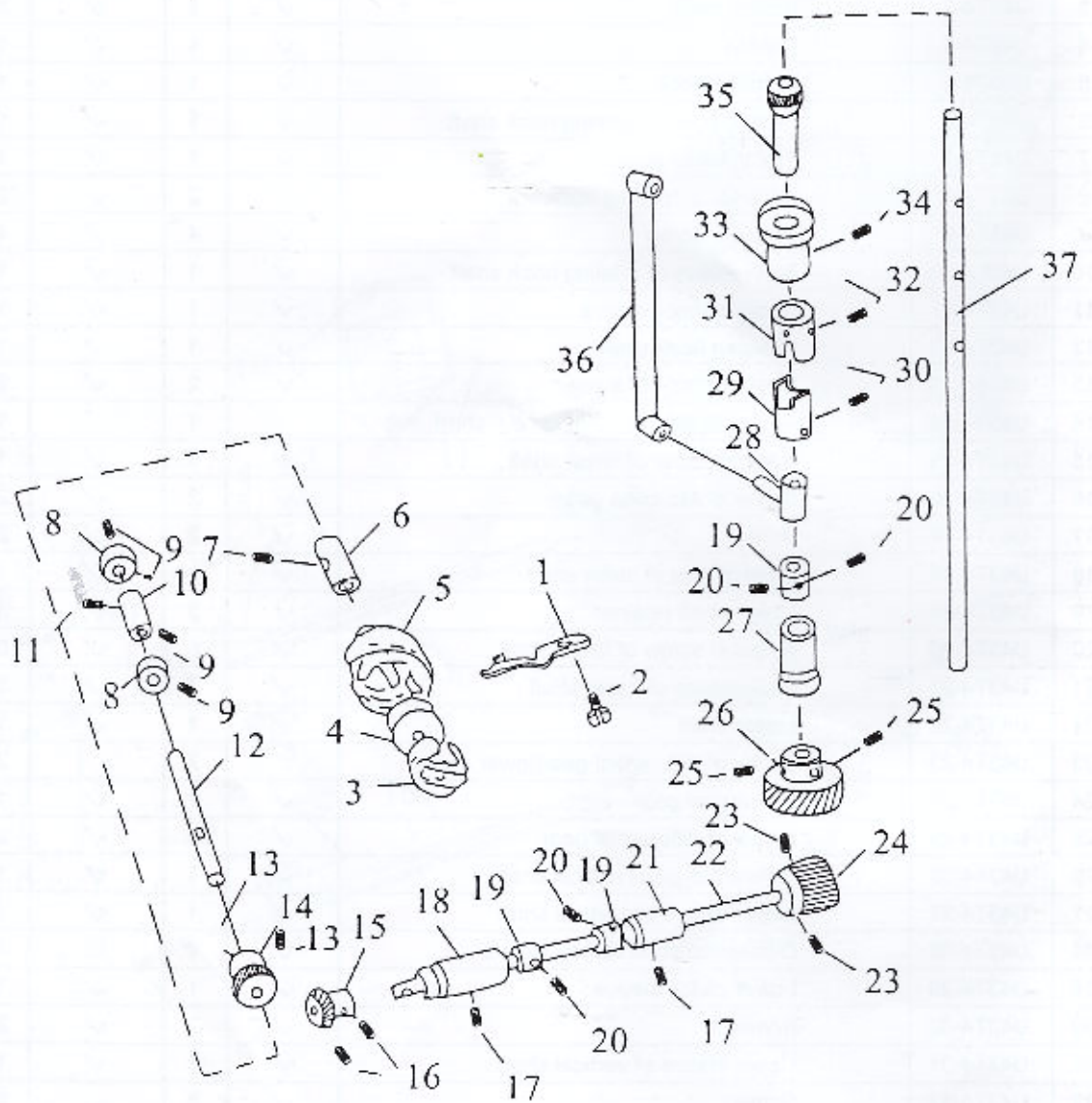

5. Components of Swaying needle

Seri No.	Code No.	Description	Products applicable			
			Curved-stitching	Qty	Double Curved-stitching	Qty
1	U43T5-1	Horizontal needle fork	✓	1	✓	1
2	U43T5-2	Shaft of swaying needle	✓	1	✓	1
3	U43T5-3	Screw	✓	1	✓	1
4	U43T5-4	Gear of swayinn needle	✓	1	✓	1
5	U43T5-5	Eccentric retainer	✓	1	✓	1
6	U43T5-6	Connecting screw	✓	2	✓	2
7	U43T5-7	Eccentric retainer	✓	1	✓	1
8	U43T5-8	Rack retainer	✓	1	✓	1
9	U43T5-9	Retainer screw	✓	2	✓	2
10	U43T5-10	Retainer shaft	✓	1	✓	1
11	U43T5-11	Connecting screw	✓	1	✓	1
12	U43T5-12	Differential connecting bar	✓	1	✓	1
13	U43T5-13	Eccentric pin of needle bar	✓	1	✓	1
14	U43T5-14	Sliding block of swaying needle	✓	1	✓	1
15	U43T5-15	Guide base of swaying needle	✓	1	✓	1
16	U43T5-16	Screw of guie base	✓	1	✓	1
17	U43T5-17	Adjustable connecting bar	✓	1	✓	1
18	U43T5-18	Connecting screw of differential connecting bar	✓	3	✓	3
19	U43T5-19	Locating block of swaying needle	✓	1	✓	1
20	U43T5-20	Connecting pin of guide	✓	2	✓	2
21	U43T5-21	Adjusting screw of locating block	✓	2	✓	2
22	U43T5-22	Fastening nut of locating crank	✓	2	✓	2
23	U43T5-23	Screw for adjusting crank sleeve	✓	1	✓	1
24	U43T5-24	Spring for adjusting crank	✓	1	✓	1
25	U43T5-25-0	Adjusting crank component	✓	1	✓	1
26	U43T5-26	Screw of spanner locating retainer	✓	2	✓	2
27	U43T5-27	Locating retainer of spanner	✓	1	✓	1
28	U43T5-28	Washer	✓	1	✓	1
29	U43T5-29	Spanner sleeve	✓	1	✓	1
30	U43T5-30/31	Spanner component	✓	1	✓	1
31	U43T5-34	Left locating block for stitch wide	✓	1	✓	1
32	U43T5-35	Right locating block for stitch wide	✓	1		
33	U43T5-36	Washer of locating block	✓	2	✓	2
34	U43T5-37	Screw of locating block	✓	2	✓	2
35	U43T5-38	Locating screw	✓	2	✓	2
36	U43T5-39	Lcating rack for stitch wide	✓	2	✓	2
37	U43T5-40	Screw of locating rack	✓	1	✓	1
38	U43T5-41	Adjusting rack (A) for stitch wide	✓	1	✓	1
39	U43T5-42	Adjusting rack (B)	✓	1	✓	1
40	U43T5-43	Extension spring of lcoating rack	✓	1	✓	1

Seri No.	Code No.	Description	Products applicable			
			Curved-stitching	Qty	Double Curved-stitching	Qty
41	U43T5-44	Petainer of differential connecting shaft	✓	1	✓	1
42	U43T5-45	Differential crank	✓	1	✓	1
43	U43T5-48	Differential connecting shaft	✓	1	✓	1
44	U43T5-49-0	Locating rack component	✓	1	✓	1
45	U43T5-50	Set screw of locating rack sleeve	✓	1	✓	1
46	U43T5-51	Screw of crank locating rack	✓	2	✓	2
47	U43T5-52	Screw of extension spring	✓	1	✓	1
48	U43T5-53	Connecting screw	✓	1	✓	1
49	U43T5-54	Oil tray	✓	1	✓	1
50	U43T5-55	Oil gauze	✓	1	✓	1
51	U43T5-56	Felt of oil tray	✓	1	✓	1
52	U43T5-57	Flat washer	✓	2	✓	2
53	U43T5-58	Screw of oil tray	✓	2	✓	2
54	U43T5-59	Elastic washer	✓	2	✓	2
55	U43T5-60	Right locating block for stitch wide			✓	1
56	U43T5-61	Locating rack	✓	1	✓	1
57	U43T5-62	Screw	✓	2	✓	2
58	U43T5-63	Handle component	✓	1	✓	1
59	U43T5-64	Locating pin	✓	1	✓	1
60	U43T5-65	Adjusting rack	✓	1	✓	1
61	U43T5-66	Screw	✓	2	✓	2
62	U43T5-67	Screw, nut	✓	2	✓	2

5. Components of Swaying needle

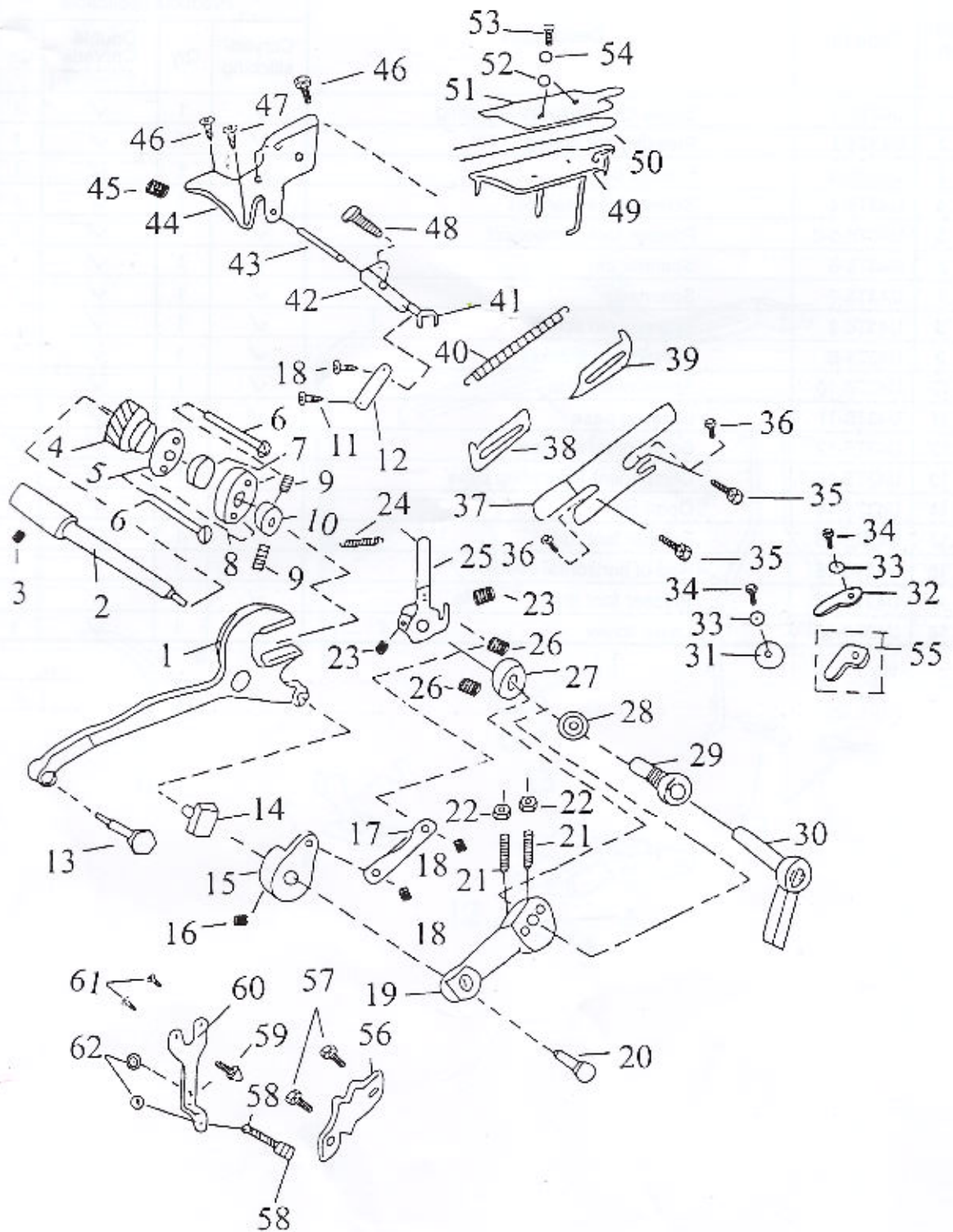

6. Components of presser foot

Seri No.	Code No.	Description	Products applicable			
			Curved-stitching	Qty	Double Curved-stitching	Qty
1	U43T6-1	Screw for pressures-adjusting	✓	1	✓	1
2	U43T6-2	Pressing bar spring	✓	1	✓	1
3	U43T6-3	Presser bar	✓	1	✓	1
4	U43T6-4	Screw of presser foot	✓	1	✓	1
5	U43T6-5-0	Presser foot component	✓	1	✓	1
6	U43T6-6	Spanner pin	✓	1	✓	1
7	U43T6-7	Spanner	✓	1	✓	1
8	U43T6-8	Spanner pin screw	✓	1	✓	1
9	U43T6-9	Presser bar bracket	✓	1	✓	1
10	U43T6-10	Screw of bracket	✓	1	✓	1
11	U43T6-11	Locating base	✓	1	✓	1
12	U43T6-12	Screw of lever base	✓	2	✓	2
13	U43T6-13-0	Component of locating base	✓	1	✓	1
14	U43T6-14	Open-pin	✓	3	✓	3
15	U43T6-15	Presser foot rod	✓	1	✓	1
16	U43T6-16	Rod of horizontal needle	✓	1	✓	1
17	U43T6-17	Presser foot lever	✓	1	✓	1
18	U43T6-18	Lever screw	✓	1	✓	1

6. Components of presser foot

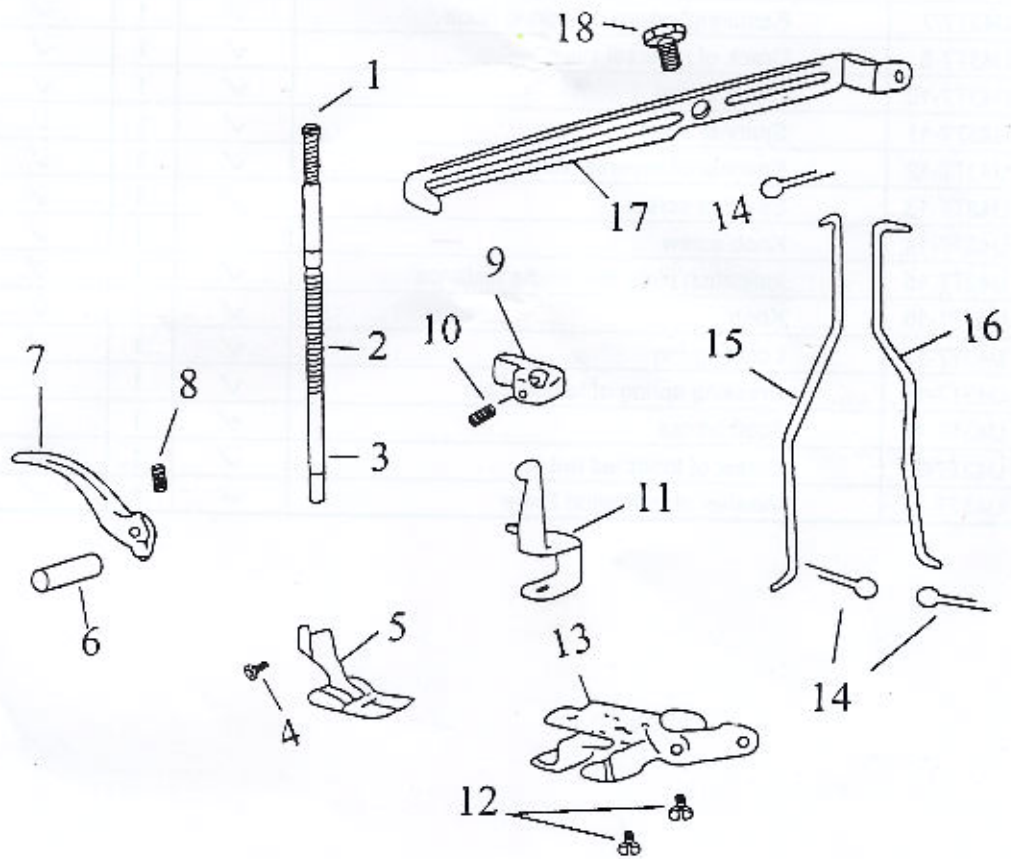

7. Components of Needle Distance of Reversal Stitch

Seri No.	Code No.	Description	Products applicable			
			Curved-stitching	Qty	Double Curved-stitching	Qty
1	U43T7-1	Feed adjusting screw	✓	1	✓	1
2	U43T7-2	Pin	✓	1	✓	1
3	U43T7-3	Set screw	✓	1	✓	1
4	U43T7-4	Feed regulator	✓	1	✓	1
5	U43T7-5	Restoring extension spring of reversal stitch	✓	1	✓	1
6	U43T7-6	Screw of extension spring hook	✓	1	✓	1
7	U43T7-7	Restoring extension-spring hook	✓	1	✓	1
8	U43T7-8	Crank of reversal stitch	✓	1	✓	1
9	U43T7-10	Crank screw	✓	1	✓	1
10	U43T7-11	Spanner shaft	✓	1	✓	1
11	U43T7-12	Spanner of reversal stitch	✓	1	✓	1
12	U43T7-13	Spanner screw	✓	1	✓	1
13	U43T7-14	Knob screw	✓	1	✓	1
14	U43T7-15	Indication plate for needle distance	✓	1	✓	1
15	U43T7-16	Knob	✓	1	✓	1
16	U43T7-17	Locating Pin	✓	1	✓	1
17	U43T7-18	Pressing spring of locating pin	✓	1	✓	1
18	U43T7-19	Toothed nut	✓	1	✓	1
19	U43T7-20	Screw of toothed nut	✓	1	✓	1
20	U43T7-21	Washer of Indication Plate	✓	1	✓	1

6. Components of presser foot

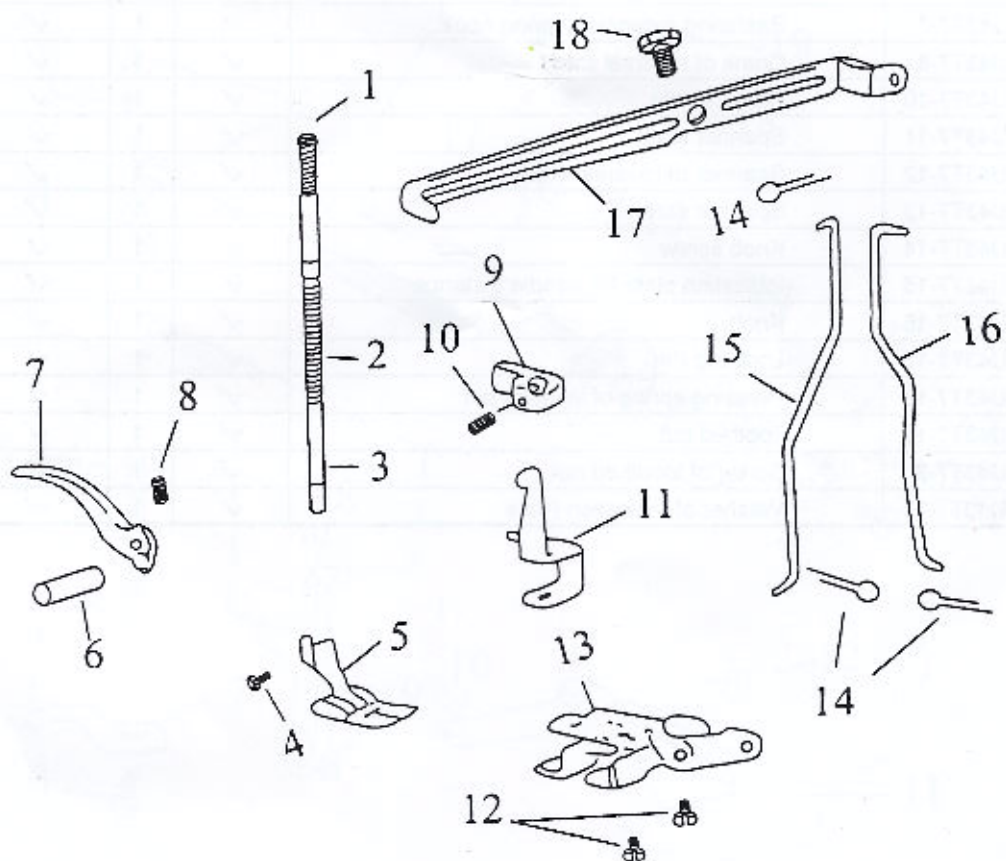

7. Components of Needle Distance of Reversal Stitch

Seri No.	Code No.	Description	Products applicable			
			Curved-stitching	Qty	Double Curved-stitching	Qty
1	U43T7-1	Feed adjusting screw	✓	1	✓	1
2	U43T7-2	Pin	✓	1	✓	1
3	U43T7-3	Set screw	✓	1	✓	1
4	U43T7-4	Feed regulator	✓	1	✓	1
5	U43T7-5	Restoring extension spring of reversal stitch	✓	1	✓	1
6	U43T7-6	Screw of extension spring hook	✓	1	✓	1
7	U43T7-7	Restoring extension-spring hook	✓	1	✓	1
8	U43T7-8	Crank of reversal stitch	✓	1	✓	1
9	U43T7-10	Crank screw	✓	1	✓	1
10	U43T7-11	Spanner shaft	✓	1	✓	1
11	U43T7-12	Spanner of reversal stitch	✓	1	✓	1
12	U43T7-13	Spanner screw	✓	1	✓	1
13	U43T7-14	Knob screw	✓	1	✓	1
14	U43T7-15	Indication plate for needle distance	✓	1	✓	1
15	U43T7-16	Knob	✓	1	✓	1
16	U43T7-17	Locating Pin	✓	1	✓	1
17	U43T7-18	Pressing spring of locating pin	✓	1	✓	1
18	U43T7-19	Toothed nut	✓	1	✓	1
19	U43T7-20	Screw of toothed nut	✓	1	✓	1
20	U43T7-21	Washer of Indication Plate	✓	1	✓	1

7. Components of Needle Distance of Reversal Stitch

